

## 2 Gang Grid Plate

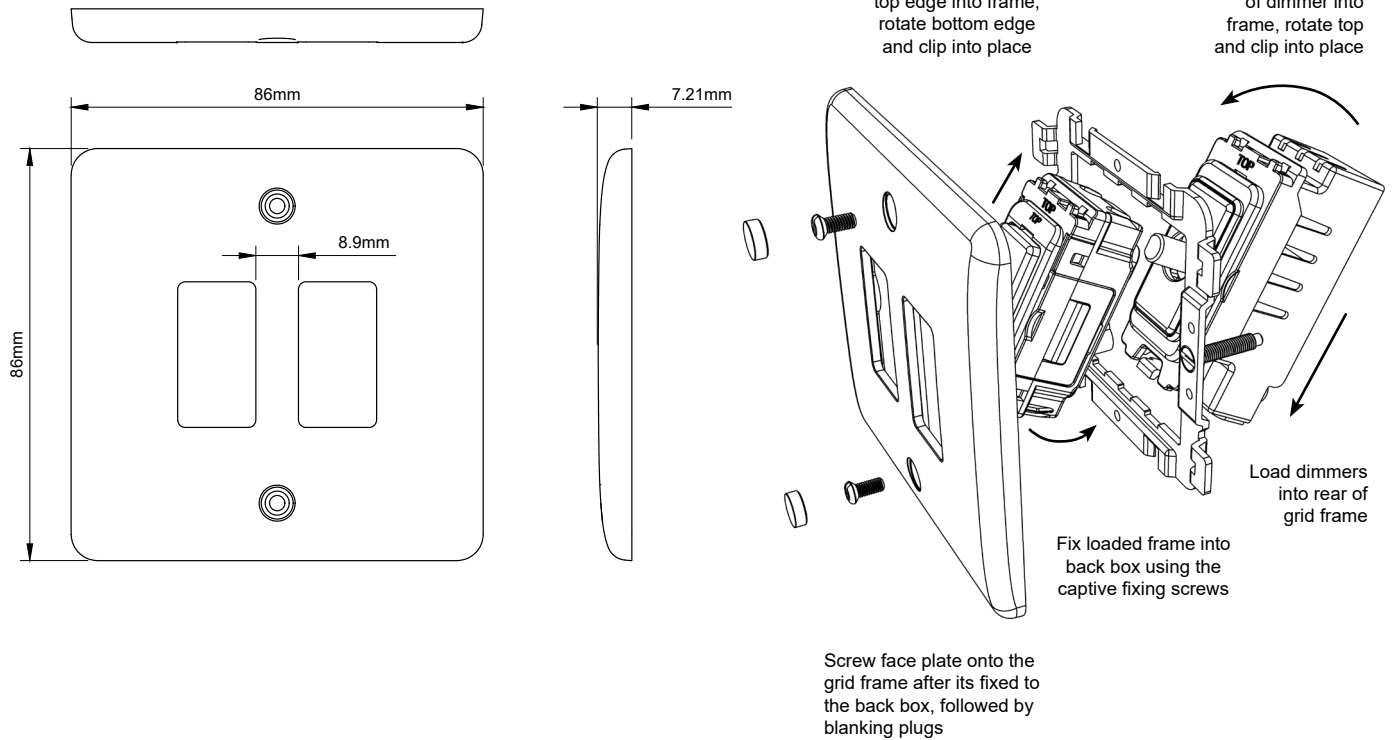

### TECHNICAL SPECIFICATION

<b>Standard(s)</b>	BS 5733 (Where Applicable)
<b>Mounting Box Depth (Min)</b>	35mm
<b>Fixing Centres</b>	60.3mm
<b>Size</b>	86mm x 86mm x 7mm (Plate thickness)
<b>Product Class 1</b>	Grid frame must be earthed
<b>Ambient Operating Temperature</b>	-5° to +40°C
<b>Recommended Location</b>	Internal Use Only
<b>Maximum Installation Altitude</b>	2000m
<b>IP Rating</b>	IP2XD
<b>Trademarks</b>	The Lieber Company is a registered trade mark number: UK00003313578 Date: 26 May 2018